

## CHECK THE DROPOUT FITTING AND THE BOTTOM BRACKET OF YOUR FRAME

DROPOUT FITTING (rear hub spacing)	BOTTOM BRACKET	K factor	INGRID SPINDLE LENGHT
<b>148 mm (boost)</b>	386EVO (86.5 mm) BSA (68/73 mm) Press Fit 30 (68/73 mm) BB30 (68/73 mm) Press Fit BB86 (86 mm) Press Fit BB92 (92 mm) Press Fit BB89.5 (89.5 mm)	<b>96.5 mm</b>	<b>L136</b>
	BSA (73 mm) Press Fit BB92 (92 mm) Press Fit BB89.5 (89.5 mm)		
<b>142 mm</b>	386EVO (86.5 mm) BSA (68 mm) Press Fit 30 (68/73 mm) BB30 (68/73 mm) Press Fit BB86 (86 mm)	<b>91.5 mm</b>	<b>L131</b>

### K FACTOR

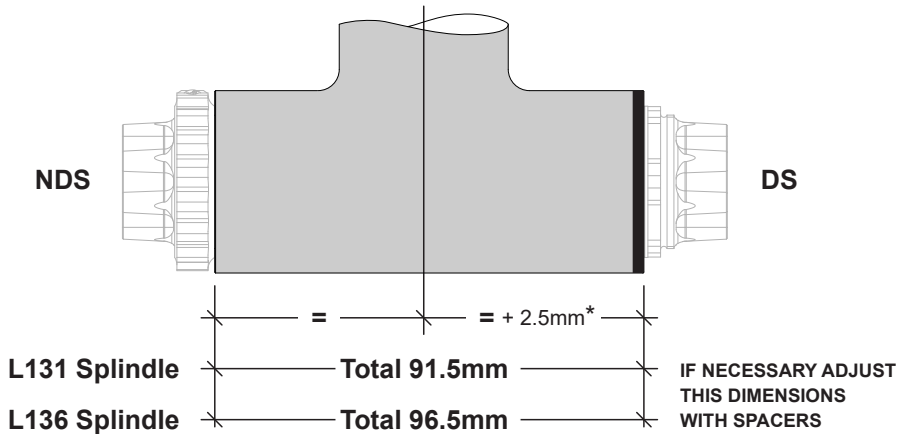

\* Our crankset system is designed following the common BB design-standard that provides an asimmetry of 2.5mm on drive side for the correct chain-line